

## CONSTANT TEMPERATURE PROCESS VESSELS

### QZ-Lite - Heated Quartz Tank High Purity Plate

The QZ Lite Series was created to provide customers with an ultra pure plate quartz tank at a price lower than a lesser quality molded tank. Imtec is able to do this by using 4mm quartz plate that is machined and fabricated in house, and limiting the options available. All QZ lite tanks come with 208-240V heaters and T/C holders in one corner. Constructing the main vessel with 4mm quartz plate not only reduces cost but allows for more efficient heat transfer with a higher level of purity.

#### Safety & Reliability:

- Redundant over-temperature thermocouples and "over-limit" thermostatic switch
- Leak detection systems built into every vessel
- Uniform, low watt-density Inconel heaters
- Alumina Silicate blanket insulation

#### Options:

- Patented AQUASEAL® Technology
- PVDF Housing
- Quartz Drain Stem, 3/4" Quartz flared connector
- Additional Quartz probe holders
- Leak Detect Module
- 20ft. Power Cord

**IMTEC** has set the global standard for static heated process vessels. Our complete line of ACCUBATH® systems deliver unsurpassed process performance, reliability, and safety in wet-systems throughout the world. IMTEC has been supplying constant temperature chemical vessels and accessories since 1982. Our commitment to engineering excellence has consistently given IMTEC's customers exceptionally dependable and advanced process equipment.

Our dedication to manufacturing process control, exemplified by our long standing ISO-9001 registration, assures our customers of consistent high-quality products in a timely manner.

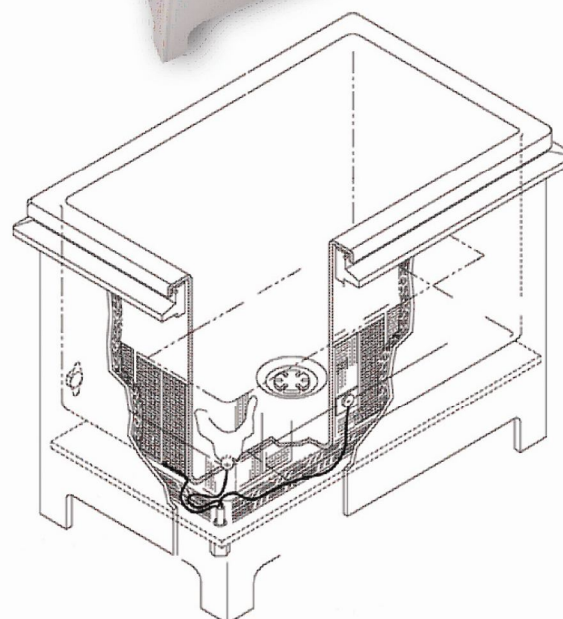
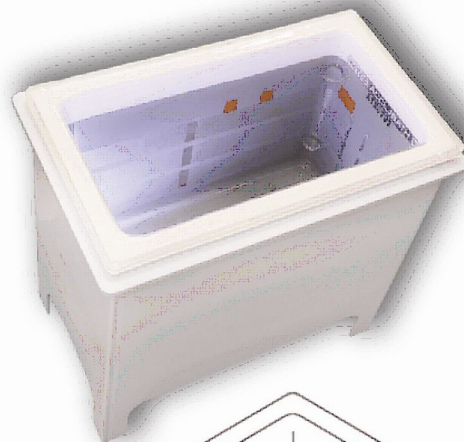

Model	Load Size*	I.D. Dim. L X W X D"
QZL-B1001	(1) 4"	7.5 x 7.25 x 6.81
QZL-A1002	(2) 4"	11.5 x 7.5 x 7.8
QZL-A1251	(1) 5"	7.5 x 7.25 x 8.62
QZL-A1252	(2) 5"	13.5 x 7.5 x 8.8
QZL-A1501	(1) 6"	7.8 x 7.8 x 9.8
QZL-B1501	(1) 6"	9.87 x 8.62 x 11
QZL-A1502	(2) 6"	16 x 8 x 9.6
QZL-A2001	(1) 8"	12 x 11 x 11.7

\* (0) indicates number of cassettes while 0" the wafer diameter.

**12 Month** limited warranty comes standard with the QZ Lite Series or **30 Month** limited Warranty when the Aquaseal option is added.